

BF 150.10

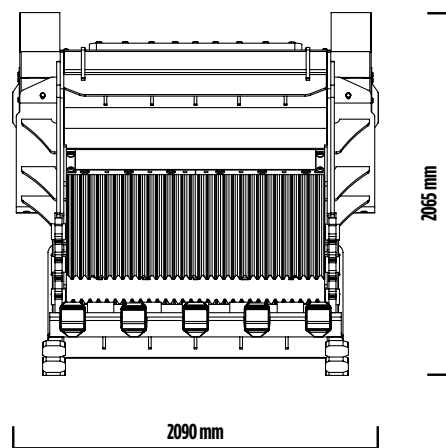

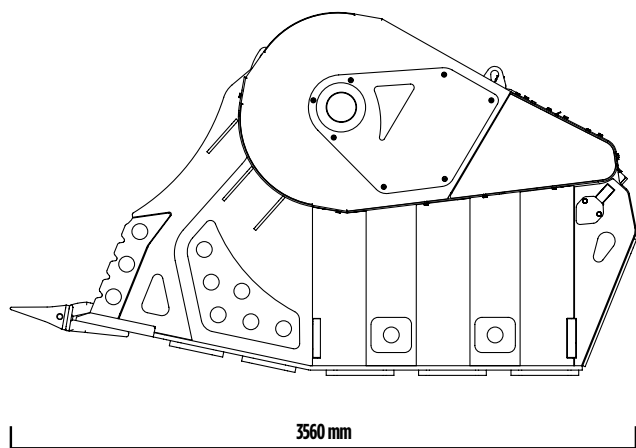

BF 150.10

One-of-a-kind for size and performance, the BF150.10 is the largest crusher bucket in the world. Ideal for applications in quarries, in the mining sector and on very large-scale sites, it guarantees the highest levels of performance and efficiency. It leaves the competition standing and has taken its place as an essential item of equipment for the primary crushing of waste materials in quarries, recycled for the repair of roadbeds, or for sale.

ACCESSORIES

- RECOMMENDED SPARE PARTS KIT
- FIX COUPLER
- HOUR METER
- 24 MONTHS WARRANTY

AREAS OF APPLICATION

- RECYCLING
- LARGE-SCALE URBAN SITES
- QUARRIES
- MINES
- DEMOLITION

SPECIFICATIONS

EQUIPMENT	LOAD CAPACITY	OPENING DIMENSIONS	OUTPUT SETTING	DIMENSIONS
 ≥ 70 Ton	2,30 m ³	L 1450 H 700 mm	≥ 100 ≤ 200 mm	3560 x 2090 H 2065mm
OIL FLOW	PRESSURE	COUNTER PRESSURE	WEIGHT	MAXIMUM PRODUCTION
380 l/min.	230 bar	10 bar	10,50 Ton	120 m ³ /h